

2W power over long distance Wireless transceiver module

Product Specificatio

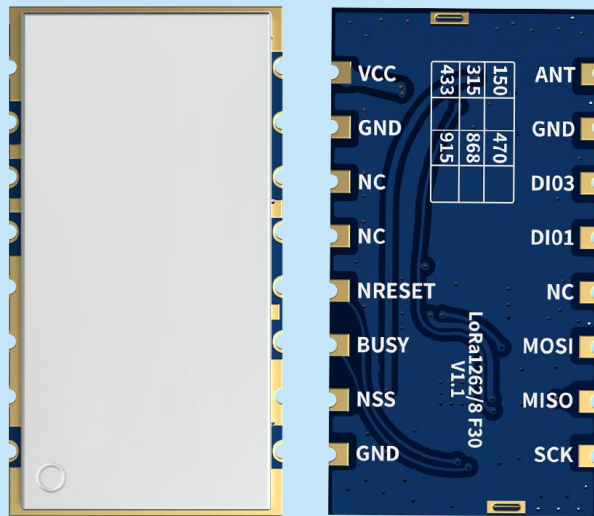

Catalogue

| | |
|---|--------|
| 1. Overview | - 3 - |
| 2. Features | - 3 - |
| 3. Applications | - 3 - |
| 4. Internal block diagram | - 3 - |
| 5. Electrical Characteristics | - 4 - |
| 6. Typical Application Circuit | - 7 - |
| 7. Rate Comparison Table | - 7 - |
| 8. Pin definition | - 8 - |
| 9. Communication Antenna | - 8 - |
| 10. Mechanical Dimensions (Unit:mm) | - 9 - |
| 11. Product order information | - 9 - |
| 12. Frequently Asked Questions | - 10 - |
| Appendix 1: SMD Reflow Chart | - 10 - |
| Appendix 2: Demo Board | - 11 - |

Note: Revision History

| Revision | Date | Comment |
|----------|------------|--|
| V1.0 | 2019-9-11 | First release |
| V1.1 | 2019-10-15 | Modify and increase some performance parameters |
| V2.0 | 2020-11 | Modify description |
| V2.1 | 2020-11 | Format updated |
| V2.2 | 2022-6 | Modify pin description |
| V2.3 | 2024-10 | Modify performance parameters |
| V2.4 | 2025-2-14 | Modify the Pin definition photo & frequency band |
| V2.5 | 2026-5 | Modify Order Information |

1. Overview

LoRa126XF30 is a wireless transceiver module with ultra-low receiving power consumption and high power, integrates Semtech RF transceiver chip SX1268/SX1262 which adopts LoRa Spread Spectrum modulation frequency hopping technique. Its communication distance and receiving sensitivity are much better than the current FSK and GFSK modulation. Multi-signal won't affect each other even in crowd frequency environment; it comes with strong anti-interference performance.

LoRa126XF30 strictly uses lead-free process for production and testing, and meets RoHS and Reach standards.

| Module Number | Built-in chip | Standard frequency band | Crystal |
|---------------|---------------|--|---|
| Lora1268F30 | SX1268 | Center 433/470 MHz Customizable 410-810 MHz | 10ppm Industrial grade crystal oscillator |
| Lora1268F30-T | SX1268 | Center 433/470 MHz Customizable 410-810 MHz | 0.5ppm TCXO Temperature compensated crystal |
| Lora1262F30 | SX1262 | Center 150/315/433/470/868/915 MHz Customizable 150-960 MHz | 10ppm Industrial grade crystal oscillator |
| Lora1262F30-T | SX1262 | Center 150/230/315/380/433/470/868/915 MHz Customizable 150-960 MHz | 0.5ppm TCXO Temperature compensated crystal |

2. Features

- Frequency Range: 150-960 MHz
- Rx Current < 5mA(7mA @TCXO)
- Sensitivity:-148dBm @LoRa
- Maximum output power:33dBm(2W)@6V
- Modulation mode: LoRa, (G)FSK
- Data transfer rate: 0.6-300 Kbps @FSK
0.018-62.5 Kbps @LoRa
- 256bytes FiFo

3. Applications

- Industrial meter reading
- Parking lot sensor management
- Industrial automation
- Agricultural sensor
- Smart city
- Warehouse management
- Street lights
- Logistics management
- Environmental sensor
- Health products
- Security products
- Remote control

4. Internal block diagram

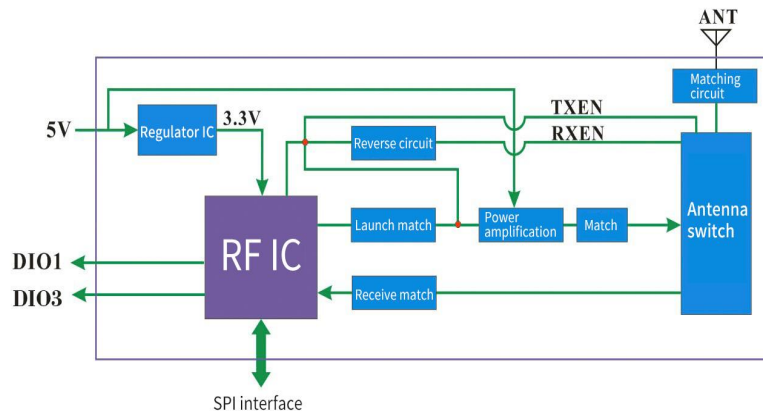

5. Electrical Characteristics

| Parameter | Min. | Typ. | Max. | Unit | Condition |
|---------------------------------|-------|------|------|------|----------------------------------|
| Operation Condition | | | | | |
| Working Voltage | 3 | 5 | 6.5 | V | |
| Temperature Range | -40 | 25 | 85 | °C | |
| Current Consumption | | | | | |
| RX Current | | < 5 | | mA | @433MHz, 470MHz @5V |
| | | < 7 | | mA | @868MHz, 915MHz @5V |
| TX Current | 500 | | 600 | mA | @5V 30dBm,433MHz,470MHz |
| | 600 | | 700 | mA | @5V 30dBm,868MHz,915MHz |
| Sleep Current | | < 2 | | uA | @433MHz, 470MHz |
| | | < 5 | | uA | @868MHz, 915MHz |
| RF Parameter | | | | | |
| Frequency Range | 150 | 150 | 180 | MHz | @150 MHz |
| | 300 | 315 | 340 | MHz | @315 MHz |
| | 400 | 433 | 460 | MHz | @433 MHz |
| | 470 | 490 | 510 | MHz | @470 MHz |
| | 848 | 868 | 888 | MHz | @868 MHz |
| | 900 | 915 | 940 | MHz | @915 MHz |
| Data Rate | 1.2 | | 300 | Kbps | @FSK |
| | 0.018 | | 62.5 | Kbps | @LoRa |
| Transmit Power | 31.5 | | 34 | dBm | @150MHz,315MHz @5V |
| | 31 | | 33 | dBm | @433MHz,470MHz @5V |
| | 29 | | 31 | dBm | @868MHz,915MHz @5V |
| Software Adjustable Power Range | 15 | | 33 | dBm | @150MHz,315MHz @5V |
| | 12 | | 32 | dBm | @433MHz,470MHz @5V |
| | 1 | | 30 | dBm | @868MHz,915MHz @5V |
| Receiving Sensitivity | | -122 | | dBm | @FSK data=1.2 Kbps Fdev=50 KHz |
| | | -139 | | dBm | @Lora BW=62.5 KHz SF = 12 CR=4/5 |

➤ The transmit power of the module can be configured by software, and the corresponding values are shown in the following table:

| Power level of DEMO board | | 0 | 1 | 2 | 3 | 4 | 5 | 6 | 7 | 8 | 9 |
|---------------------------|-------------|------|------|------|------|------|------|------|------|------|------|
| Register value | | -5 | -2 | 1 | 4 | 7 | 10 | 13 | 16 | 19 | 22 |
| @150MHz @5V | Power (dBm) | 15.5 | 18.0 | 20.7 | 23.5 | 26.2 | 28.4 | 30.5 | 31.9 | 32.2 | 32.3 |
| | Current(mA) | 205 | 217 | 236 | 290 | 382 | 499 | 632 | 753 | 803 | 812 |
| @315MHz @5V | Power (dBm) | 15.7 | 18.1 | 20.6 | 23.4 | 26.1 | 28.7 | 31.0 | 32.3 | 32.7 | 33.0 |
| | Current(mA) | 204 | 212 | 227 | 260 | 320 | 416 | 527 | 605 | 637 | 644 |
| @433MHz @5V | Power (dBm) | 11.4 | 13.2 | 16.5 | 19.3 | 22.2 | 25.0 | 27.6 | 29.6 | 30.9 | 31.6 |
| | Current(mA) | 246 | 255 | 260 | 276 | 304 | 364 | 454 | 554 | 630 | 689 |
| @470MHz @5V | Power (dBm) | 11.4 | 14.5 | 17.2 | 20.3 | 23.0 | 25.7 | 28.2 | 30.1 | 31.2 | 31.7 |
| | Current(mA) | 217 | 220 | 230 | 247 | 281 | 344 | 435 | 525 | 594 | 648 |
| @868MHz @5V | Power (dBm) | 1.4 | 4.0 | 7.1 | 10.5 | 13.7 | 17.2 | 20.5 | 23.6 | 27.5 | 29.8 |
| | Current(mA) | 89 | 99 | 113 | 136 | 169 | 214 | 278 | 361 | 504 | 670 |
| @915MHz @5V | Power (dBm) | 0 | 2.7 | 6.2 | 9.8 | 13.8 | 17.4 | 20.8 | 23.8 | 27.3 | 29.8 |
| | Current(mA) | 76 | 87 | 104 | 128 | 167 | 217 | 284 | 365 | 508 | 614 |

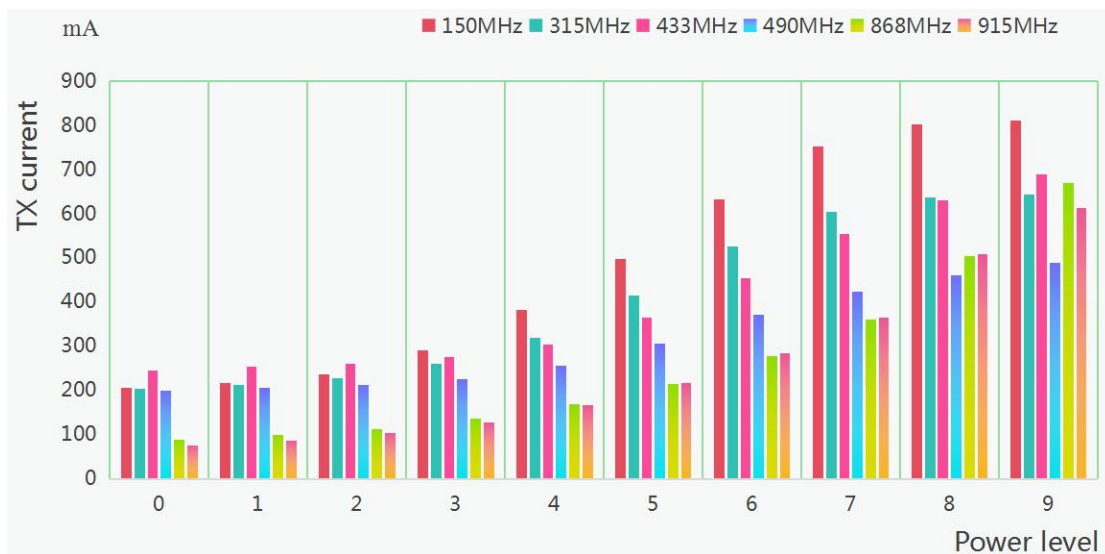
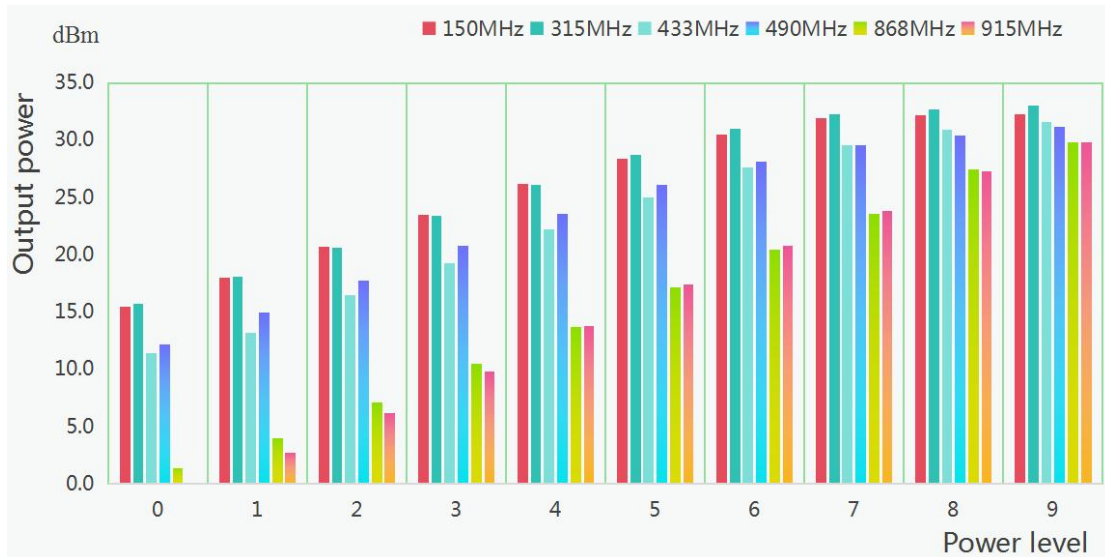

➤ Power and current comparison chart of the module at different operating voltages.

| Lora126XF30 | Supply Voltage(V) | 3.0 | 3.3 | 3.7 | 4.0 | 4.3 | 4.6 | 5.0 | 5.5 | 6.0 |
|--------------------|-------------------|------|------|------|------|------|------|------|------|------|
| @150MHz | Power(dBm) | 25.3 | 27.4 | 29.5 | 30.2 | 30.8 | 31.3 | 32 | 32.7 | 33.4 |
| | Current(mA) | 381 | 477 | 602 | 655 | 697 | 738 | 790 | 855 | 917 |
| @315MHz | Power(dBm) | 26.2 | 27.7 | 29.5 | 30.2 | 30.9 | 31.4 | 32.2 | 33 | 33.8 |
| | Current(mA) | 314 | 349 | 457 | 493 | 527 | 559 | 601 | 655 | 712 |
| @868MHz @915MHz | Power(dBm) | 24.4 | 25.8 | 27.5 | 28.2 | 28.7 | 29.1 | 29.6 | 30.2 | 30.5 |
| | Current(mA) | 408 | 472 | 555 | 606 | 640 | 657 | 681 | 705 | 726 |
| @433MHz @470MHz | Power(dBm) | 27.7 | 28.7 | 29.8 | 29.9 | 30.9 | 31.4 | 32.0 | 32.6 | 33.2 |
| | Current(mA) | 430 | 485 | 550 | 560 | 601 | 630 | 651 | 712 | 750 |

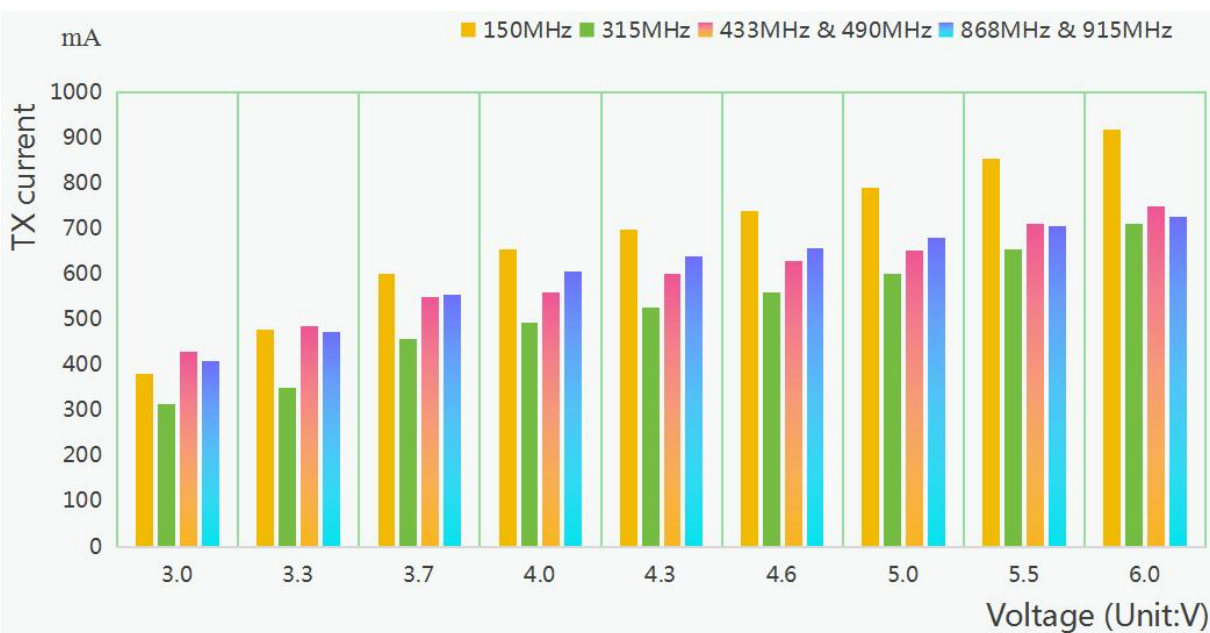
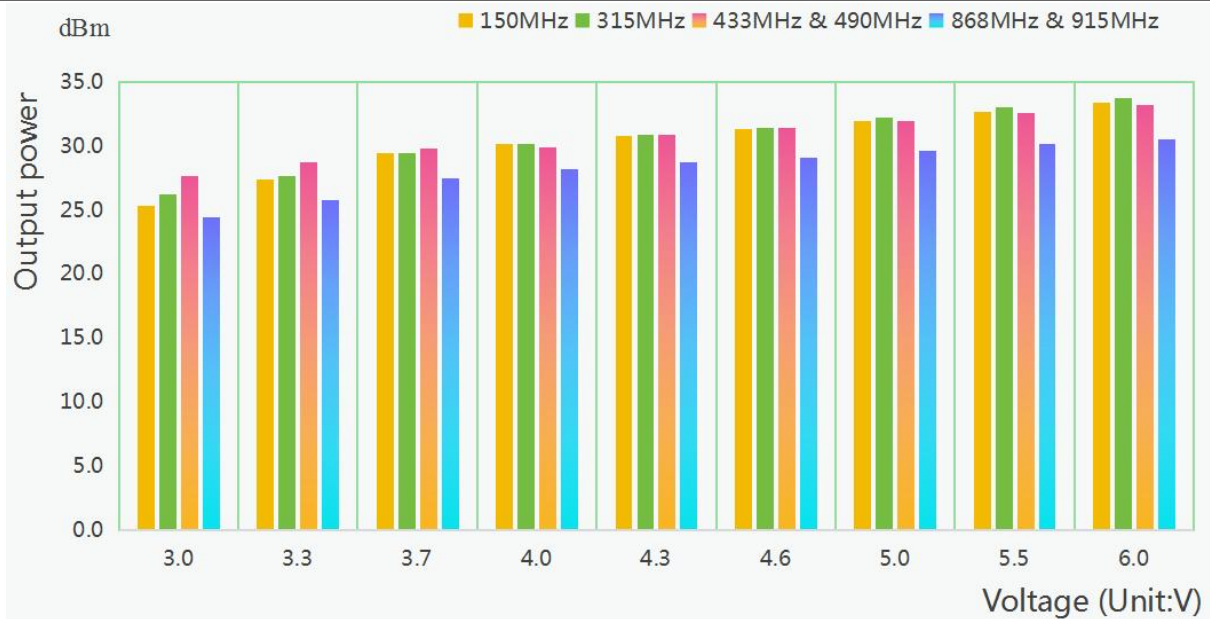

6. Typical Application Circuit

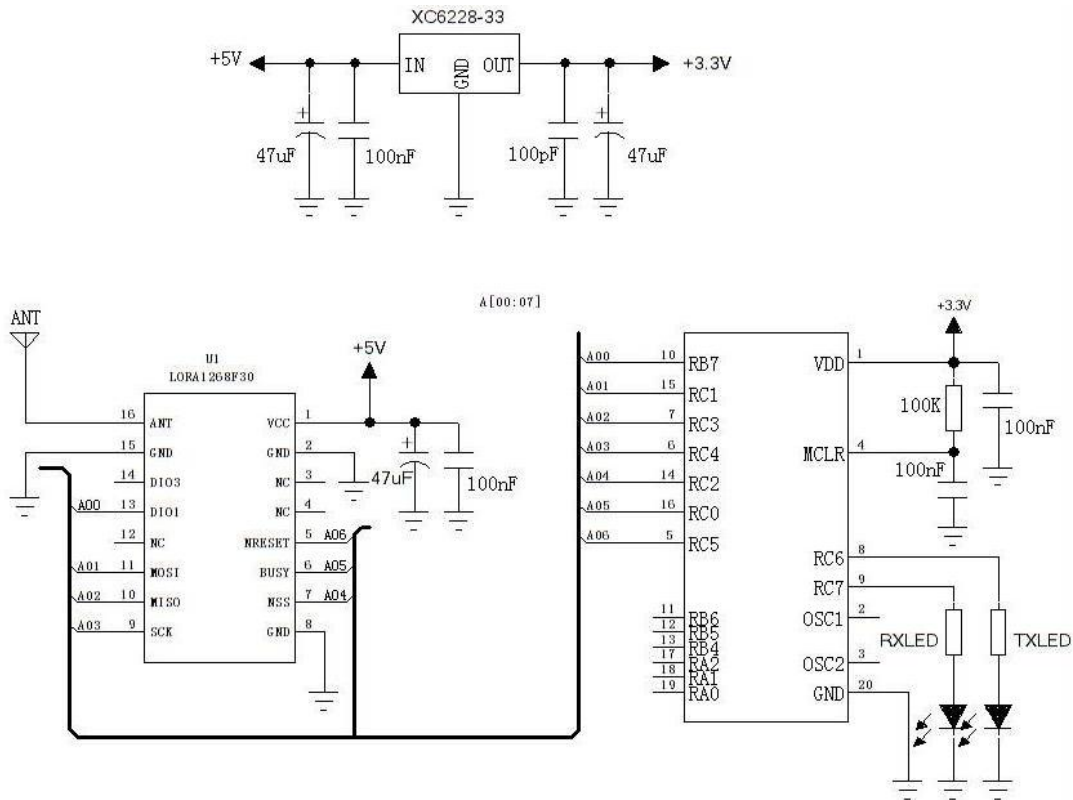

7. Rate Comparison Table

| SignalBandWidth | SpreadingFactor | Sensitivity(dbm) | ActualBandRate(bps) |
|-----------------|-----------------|------------------|---------------------|
| 62.5kHz | SF=7 | -126 | 2169 |
| 62.5kHz | SF=8 | -129 | 1187 |
| 62.5kHz | SF=9 | -132 | 656 |
| 62.5kHz | SF=10 | -135 | 296 |
| 62.5kHz | SF=11 | -137 | 164 |
| 62.5kHz | SF=12 | -139 | 91 |
| 125kHz | SF=7 | -123 | 4338 |
| 125kHz | SF=8 | -126 | 2375 |
| 125kHz | SF=9 | -129 | 1312 |
| 125kHz | SF=10 | -132 | 733 |
| 125kHz | SF=11 | -133 | 328 |
| 125kHz | SF=12 | -136 | 183 |
| 250kHz | SF=7 | -120 | 8676 |
| 250kHz | SF=8 | -123 | 4750 |
| 250kHz | SF=9 | -125 | 2624 |
| 250kHz | SF=10 | -128 | 1466 |
| 250kHz | SF=11 | -130 | 778 |
| 250kHz | SF=12 | -133 | 366 |
| 500kHz | SF=7 | -118 | 17353 |
| 500kHz | SF=8 | -121 | 9501 |
| 500kHz | SF=9 | -124 | 5249 |
| 500kHz | SF=10 | -127 | 2932 |
| 500kHz | SF=11 | -129 | 1557 |
| 500kHz | SF=12 | -130 | 830 |

8. Pin definition

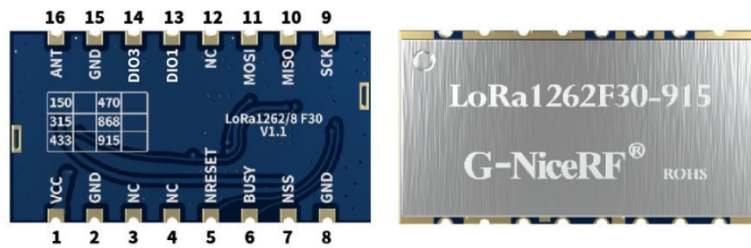

| Pin NO. | Pin name | Description |
|---------|----------|---|
| 1 | VCC | Power Supply |
| 2 | GND | Ground |
| 3,4,12 | NC | Empty |
| 5 | NRESET | power ground |
| 6 | BUSY | Used for status indication, see chip data for details. |
| 7 | NSS | SPI enable |
| 8 | GND | power ground |
| 9 | SCK | Serial clock for SPI interface |
| 10 | MISO | SPI Output for SPI data |
| 11 | MOSI | SPI Input for SPI data |
| 13 | DIO1 | Can be customized as interrupt signal indication, see chip data for details |
| 14 | DIO3 | Can be customized as interrupt signal indication, see chip data for details |
| 15 | GND | power ground |
| 16 | ANT | Connect with 50 ohm coaxial antenna |

9. Communication Antenna

Antenna is very important for RF communication, its performance will affect the communication directly. Module needs antenna in 50ohm. Common antennas have spring antennas, and external antennas can also be transferred via SMA, Users can order accordingly. To ensure module in the best performance, we suggest to use the our antenna.

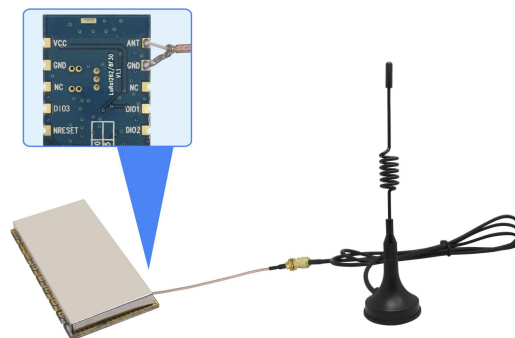

★ To ensure modules get the best performance, user must obey the following principles when using the antennas:

- Put the antenna away from the ground and obstacles as possible as you could;
- If you choose the sucker antenna, pull straight the lead wire as possible as it can be, the sucker under arches should be attached on the metal object.

10. Mechanical Dimensions (Unit:mm)

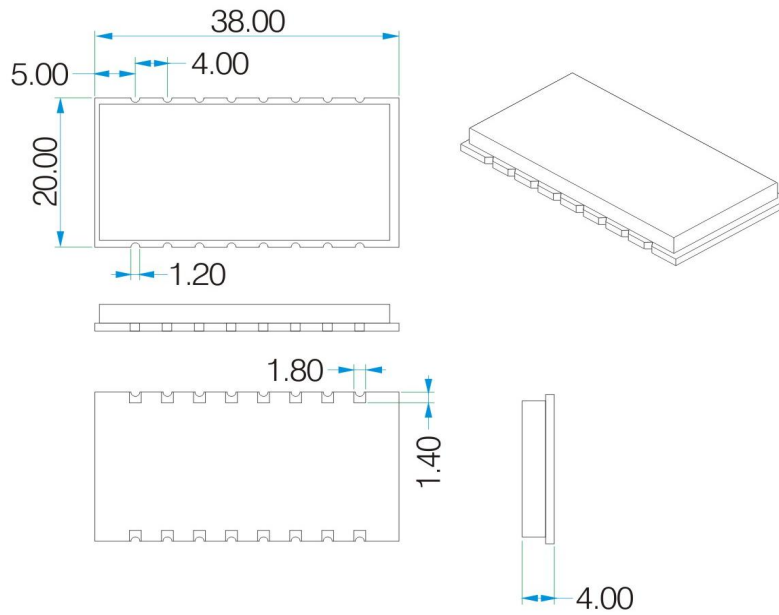

11. Product order information

LoRa1268F30-433

Module model

Frequency

For example: If the customer needs 470MHz Frequency with industrial grade crystal oscillator, the order No. shall be LoRa1268F30-470.

Currently LORA126XF30 products have the following modules:

| Product Name | Description |
|-------------------|--|
| LoRa1262F30-150 | SX1262 chip,10ppm Industrial grade crystal oscillator, 150MHz |
| LoRa1262F30-150-T | SX1262 chip,0.5ppm TCXO, 150MHz |
| LoRa1262F30-240-T | SX1262 chip,0.5ppm TCXO, 240MHz |
| LoRa1262F30-315 | SX1262 chip,10ppm Industrial grade crystal oscillator, 315MHz |
| LoRa1262F30-315-T | SX1262 chip,0.5ppm TCXO, 315MHz |
| LoRa1262F30-380-T | SX1262 chip,0.5ppm TCXO, 380MHz |
| LoRa1262F30-433 | SX1262 chip,10ppm Industrial grade crystal oscillator, 433MHz |
| LoRa1262F30-433-T | SX1262 chip,0.5ppm TCXO, 433MHz |
| LoRa1262F30-470 | SX1262 chip,10ppm Industrial grade crystal oscillator, 470MHz |
| LoRa1262F30-470-T | SX1262 chip,0.5ppm TCXO, 470MHz |
| LoRa1262F30-868 | SX1262 chip,10ppm Industrial grade crystal oscillator, 868MHz |
| LoRa1262F30-868-T | SX1262 chip,0.5ppm TCXO, 868MHz |
| LoRa1262F30-915 | SX1262 chip,10ppm Industrial grade crystal oscillator, 915MHz |
| LoRa1262F30-915-T | SX1262 chip,0.5ppm TCXO, 915MHz |
| LoRa1268F30-433 | SX1268 chip, 10ppm Industrial grade crystal oscillator, 433MHz |
| LoRa1268F30-433-T | SX1268 chip,0.5ppm TCXO, 433MHz |
| LoRa1268F30-470 | SX1268 chip, 10ppm Industrial grade crystal oscillator,470MHz |
| LoRa1268F30-470-T | SX1268 chip,0.5ppm TCXO, 470MHz |

12. Frequently Asked Questions

- a) Why can't the normal communication between the modules?
- 1) The power connection is wrong and the module is not working normally;
 - 2) Check whether the frequency bands of each module and other RF parameters are consistent;
 - 3) Whether the module is damaged.
- b) Why is the transmission distance not far?
- 1) The power supply ripple is too large;
 - 2) The antenna type is not matched or installed incorrectly;
 - 3) Surrounding co-channel interference;
 - 4) The surrounding environment is harsh and there are strong interference sources.

Appendix 1: SMD Reflow Chart

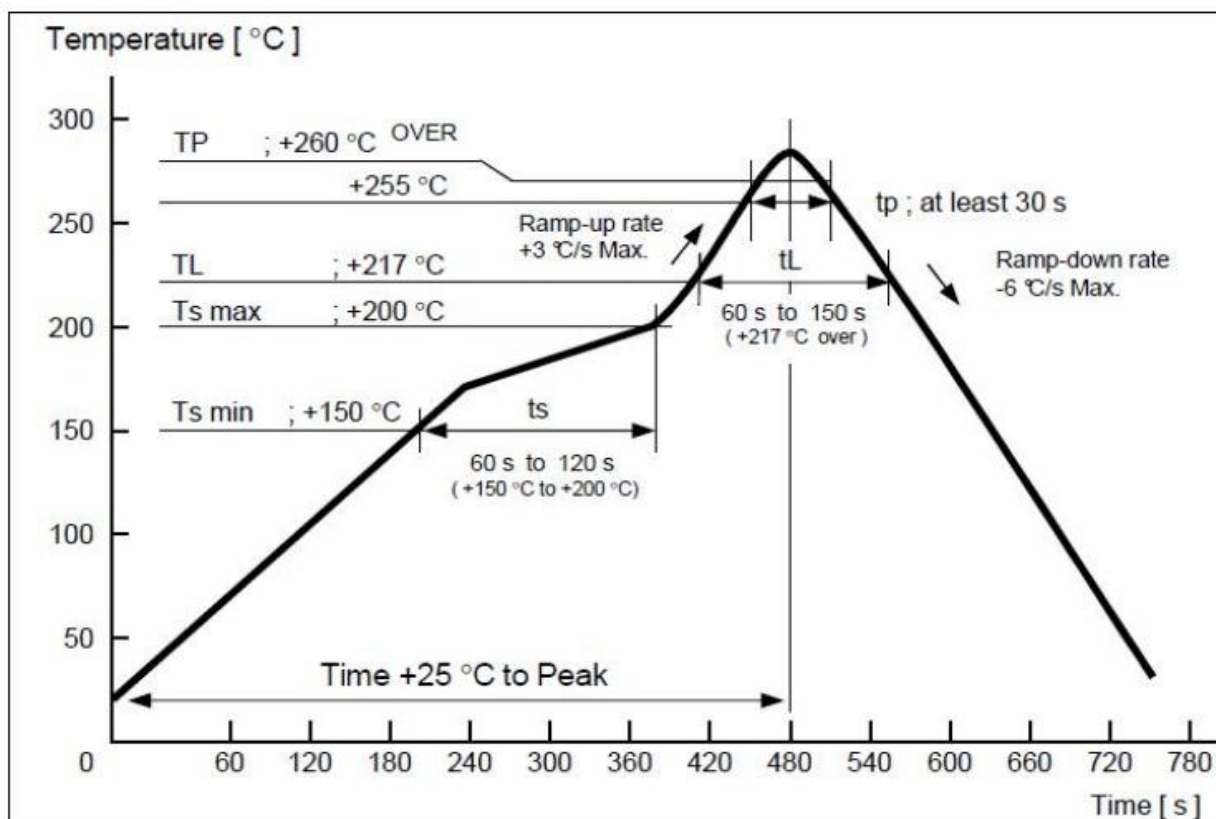

Appendix 2: Demo Board

The module is equipped with a standard DEMO board for customer to debug the program and test distance. The power supply voltage range: 3.3V~6.0V.

It shows as below:

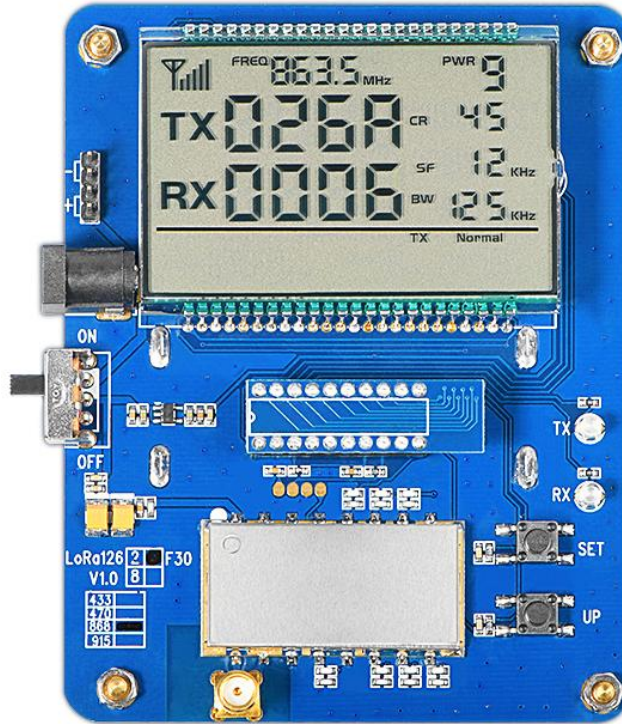

The LCD Full Segment is as below:

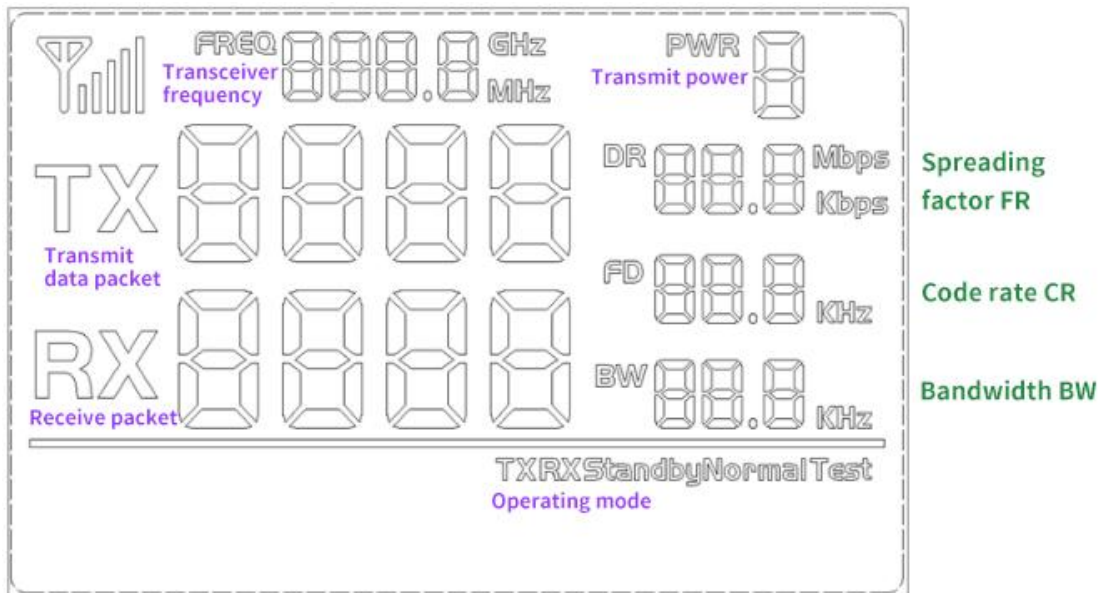

The users can set the parameters of the RF module such as frequency /transmitter power / transmission data rate through the buttons.

➤ **Working Mode:**

- 1) Tx normal mode: send data packets regularly (In the setting mode, data packets will not be sent);
- 2) Rx normal mode: Power on and enter the receive state, receive data packets, and then send out the correctly received data packets;
- 3) Tx Test Mode: RF module continuously transmit signal;
- 4) Rx Test Mode: RF module is always in Rx mode;
- 5) Standby Mode: RF module is always in standby state.

➤ **Button Operation:**

- 1) [SET] Button

Press the key to enter the setting mode. If the last parameter is set, the key will exit the setting mode.

- 2) UP Button

In setting mode, press to modify the corresponding setting parameters.

Note: The DEMO board has FLASH memory inside, all the setting parameters will behave automatically and keep unchanged even power-off.